

Candidate Name	Centre Number	Candidate Number
		0



GCSE

185/07

**MATHEMATICS
FOUNDATION TIER
PAPER 1**

P.M. MONDAY, 7 June 2010

2 hours

**CALCULATORS ARE
NOT TO BE USED
FOR THIS PAPER**

For Examiner's use only		
Question	Maximum Mark	Mark Awarded
1	10	
2	5	
3	3	
4	4	
5	8	
6	3	
7	7	
8	4	
9	6	
10	8	
11	6	
12	10	
13	4	
14	3	
15	6	
16	6	
17	4	
18	3	
TOTAL MARK		

INSTRUCTIONS TO CANDIDATES

Write your name, centre number and candidate number in the spaces at the top of this page.

Answer **all** the questions in the spaces provided.

Take π as 3.14.

INFORMATION FOR CANDIDATES

You should give details of your method of solution when appropriate.

Unless stated, diagrams are not drawn to scale.

Scale drawing solutions will not be acceptable where you are asked to calculate.

The number of marks is given in brackets at the end of each question or part-question.

Formula List

Area of trapezium = $\frac{1}{2}(a + b)h$

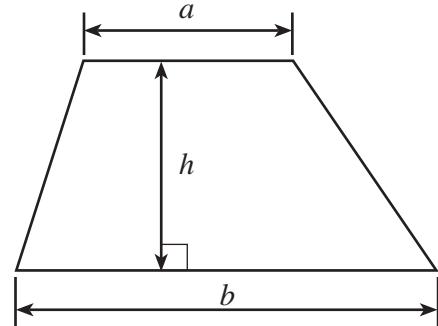

Volume of prism = area of cross-section \times length

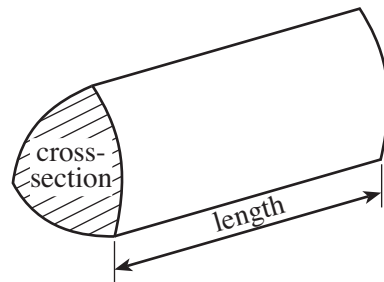

1. (a) (i) Write down, in figures, the number twelve thousand, three hundred and fourteen.

.....

(ii) Write down, in words, the number 651 300.

.....

[2]

(b) Using only the numbers in the following list,

43 12 55 54 37 16 47

write down

(i) two numbers that add up to 90,

.....

(ii) two numbers with a difference of 25,

.....

(iii) a multiple of 5,

.....

(iv) a square number.

.....

[4]

(c) Write 6579 correct to the nearest 10.

.....

[1]

(d) Write down the percentage of the following shape that has been shaded.



..... %

[1]

(e) Write down all the factors of 35.

.....

.....

.....

[2]

2. (a) Write down the next term in **each** of the following sequences.

(i) 4, 11, 18, 25,

(ii) 90, 84, 78, 72,

.....

.....

[2]

(b) Write 70% as a decimal.

Write $\frac{3}{4}$ as a decimal.

Write 70%, $\frac{3}{4}$ and 0.73 in ascending order.

.....

.....

.....

.....

[3]

3.

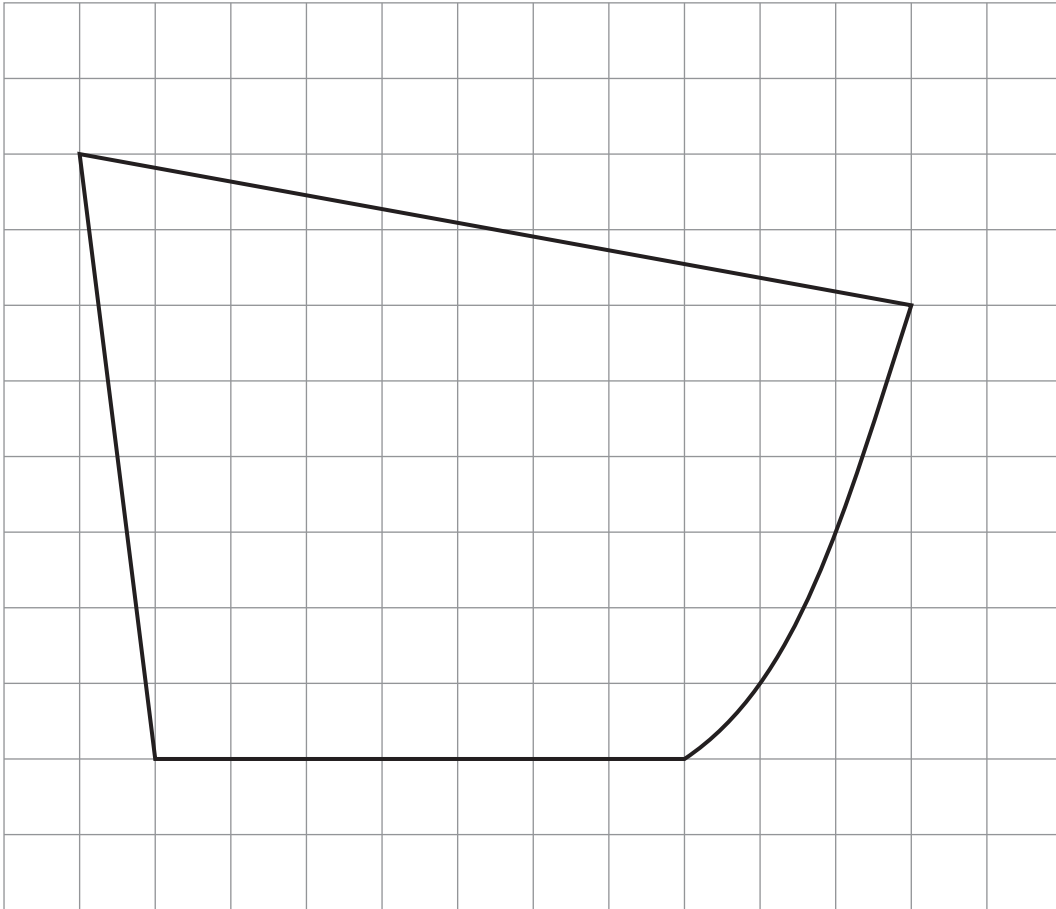

The above shape has been drawn on a centimetre square grid.

By counting squares, estimate the area of the above shape and **write down the units of your answer.**

.....

.....

.....

.....

Area of the shape = [3]

4. (a) Mark a point E on the line given below so that $DE = 9.8$ cm.

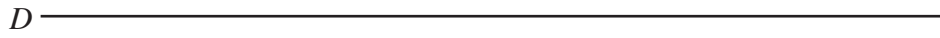

[1]

- (b) Using the diagram below,

- (i) measure and write down the size of the angle marked x ,

$x = \dots\dots\dots^\circ$

- (ii) draw a line from A so that it makes an angle of 42° with AB and forms triangle ABC .

Measure and write down the length of AC .

$AC = \dots\dots\dots$ cm

[3]

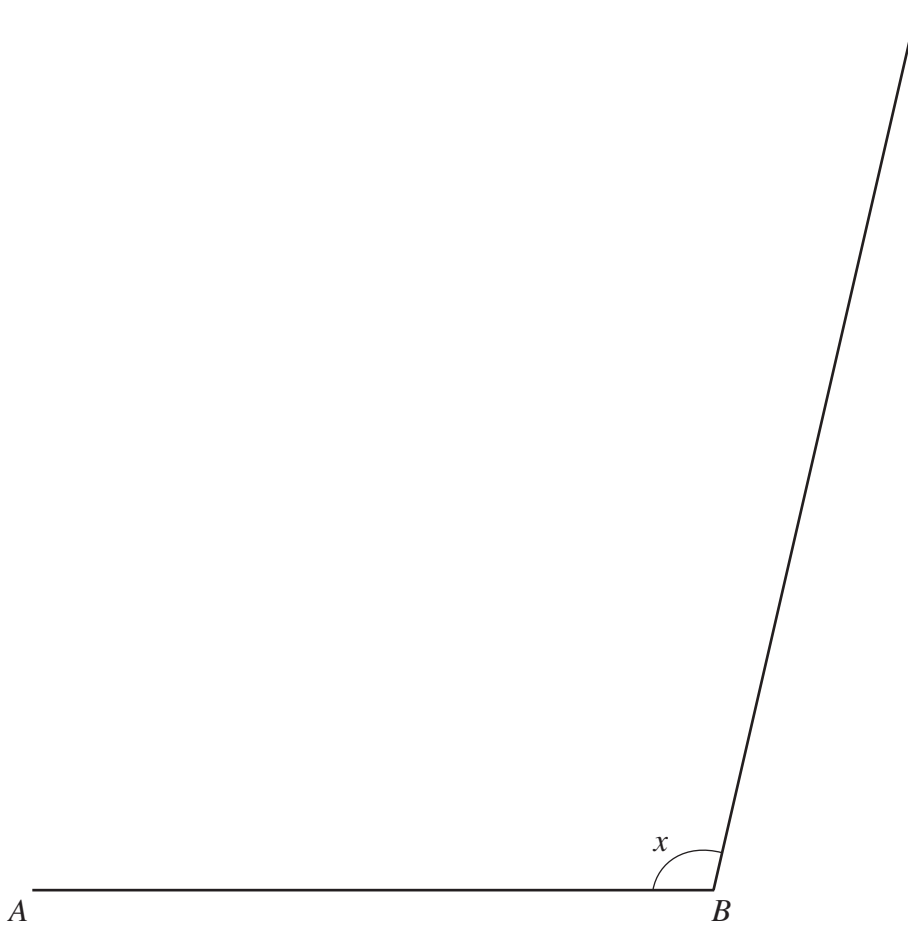

5. (a) Choose the best word from those given below to complete the following sentences.

impossible unlikely an even chance likely certain

- (i) It is that the sun will rise tomorrow.
- (ii) It is that I get a head when a coin is tossed.
- (iii) It is that I score a total of 1 when two dice are thrown.
- (iv) I buy one ticket in a raffle in which a total of 1000 tickets are sold.
It is that I will win the top prize.

[4]

(b)

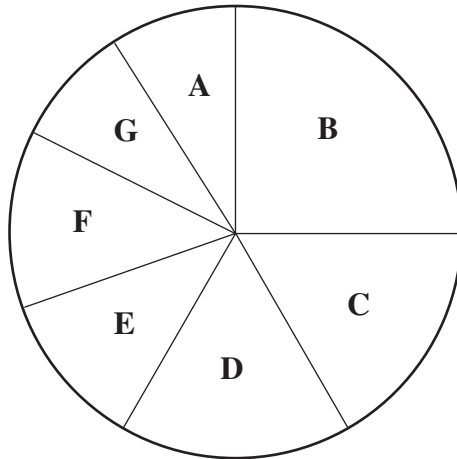

The pie chart shows the distribution of GCSE grades in mathematics obtained by the Year 11 pupils at Abercwm Comprehensive School.

(i) What **fraction** of the pupils gained grade B?

.....

.....

.....

.....

(ii) There are 240 pupils in Year 11.
How many pupils gained grade C or grade D?

.....

.....

.....

.....

[4]

6. On the graph paper below, plot the points $A(5, 1)$, $B(-3, 0)$ and $C(-2, -3)$.

[3]

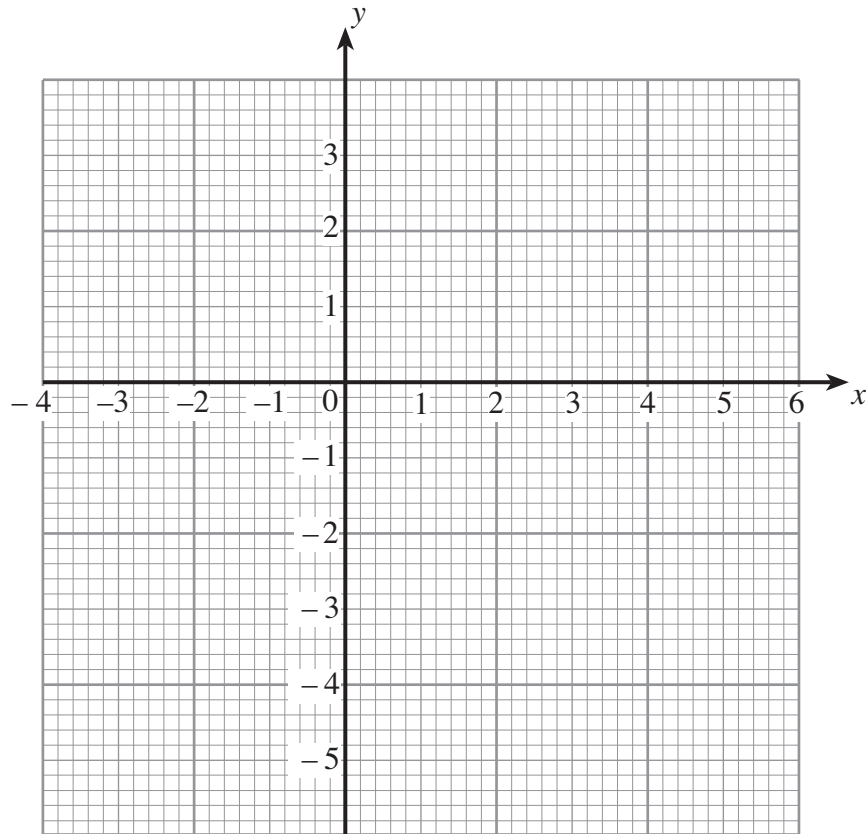

7. The following patterns have been made using black and white discs.

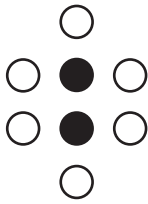

Pattern 1

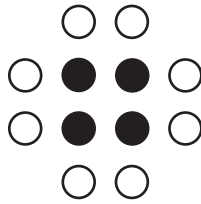

Pattern 2

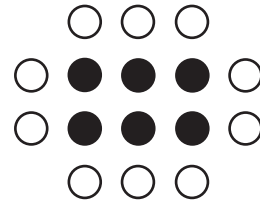

Pattern 3

(a) Draw Pattern 4 in the space below.

[1]

(b) Complete the following table.

Pattern number	1	2	3	4	5
Number of black discs	2	4	6		
Number of white discs	6	8	10		

[2]

(c) (i) Without drawing it, write down the number of the pattern that has 16 black discs.

.....

.....

.....

(ii) Write down the number of white discs in the pattern that has 16 black discs.

.....

.....

.....

[4]

8. In the following table, the letters **a**, **b**, **c** and **d** represent different numbers. The total for each row is given at the side of the table. Find the values of **a**, **b**, **c** and **d**.

a	a	a	a	20
a	a	a	b	17
b	b	c	c	12
a	b	c	d	18

.....

.....

.....

.....

.....

a = **b** = **c** = **d** =

[4]

9. (a) The seating plan for the school concert consists of 47 rows of seats with 36 seats in each row.
Calculate the total number of seats.

.....

.....

.....

.....

.....

.....

.....

.....

.....

.....

.....

.....

.....

.....

.....

.....

.....

[3]

- (b) Calculate $\frac{4}{9}$ of 72.

.....

.....

.....

[2]

- (c) Which whole number is nearest to the value of $\sqrt{101}$?

.....

.....

[1]

10. (a) Use the fact that $37 \times 52 = 1924$ to write down the answers to the following.

(i) $3.7 \times 5.2 =$

.....

(ii) $37 \times 520 =$

.....

(iii) $192.4 \div 37 =$

.....

[3]

(b) Find the value of

(i) $2^3 \times 5^3$

.....

.....

.....

.....

(ii) $12.6 - 3.58$

.....

.....

.....

.....

[3]

(c) Write down the following numbers correct to 2 significant figures.

(i) 6429

.....

(ii) 0.05283

.....

[2]

11. (a) $ABCD$ is a kite. Calculate the size of the angle marked x .

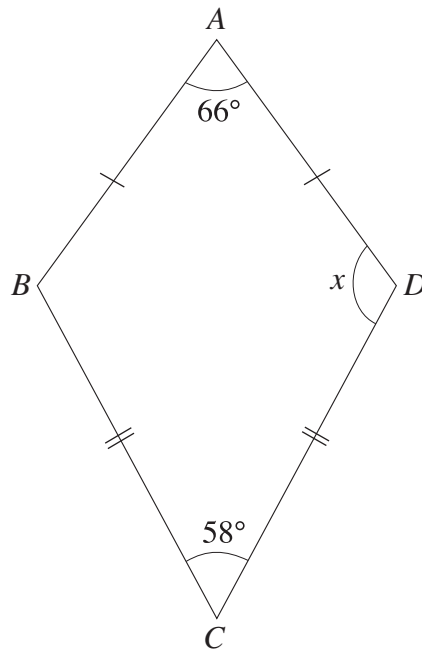

.....

.....

.....

.....

[3]

- (b) A cone is labelled **P**.
 A tetrahedron is labelled **Q**.
 A square-based pyramid is labelled **R**.
 A cuboid is labelled **S**.
 Complete the following table. One has been done for you.

Property of the shape	Label on shape
It has one circular face	P
All its faces are rectangles	
It has exactly 5 vertices	
All its faces are triangles	

[3]

12. In a game, a player throws two fair dice, one coloured white and the other coloured red. The score for the throw is the greater of the two numbers showing on the dice.

For example, if the white dice shows 4 and the red dice shows 2, the score for the throw is 4; if both the white and red dice show 2, the score for the throw is 2.

- (a) Complete the following table to show all the possible scores.

	6	6	6	6	6	6
	5	5	5	5	5	6
Red	4	4	4	4	4	6
dice	3	3	3	3	3	6
	2	2	2	3	3	6
	1	1	2	3	3	6
		1	2	3	4	5
						6

White dice

[2]

- (b) (i) What is the probability that a player scores 3?

.....

- (ii) What is the probability that a player does not score 3?

.....

[3]

A player wins a prize by getting a score of 2 or less.

- (c) Alex plays the game once. What is the probability that he wins a prize?

.....

.....

[1]

- (d) (i) 360 people each play the game once.
Approximately how many people would you expect to win a prize?

.....
.....
.....

- (ii) It costs £1 to play the game once. The prize for winning is £5. If the 360 people each play the game once, approximately how much profit do you expect the game to make?

.....
.....
.....
.....
.....

[4]

13. The sum of the two numbers in the squares is shown in the circle.
The product of the two numbers in the squares is shown in the cross.

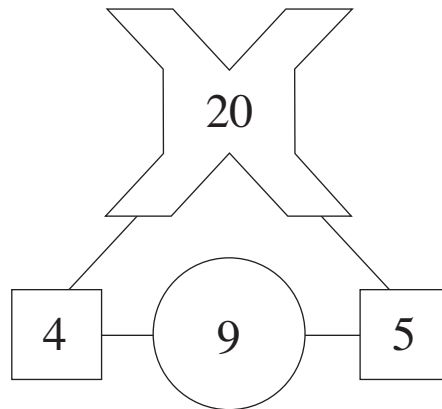

- (a) Complete **each** of the following diagrams.

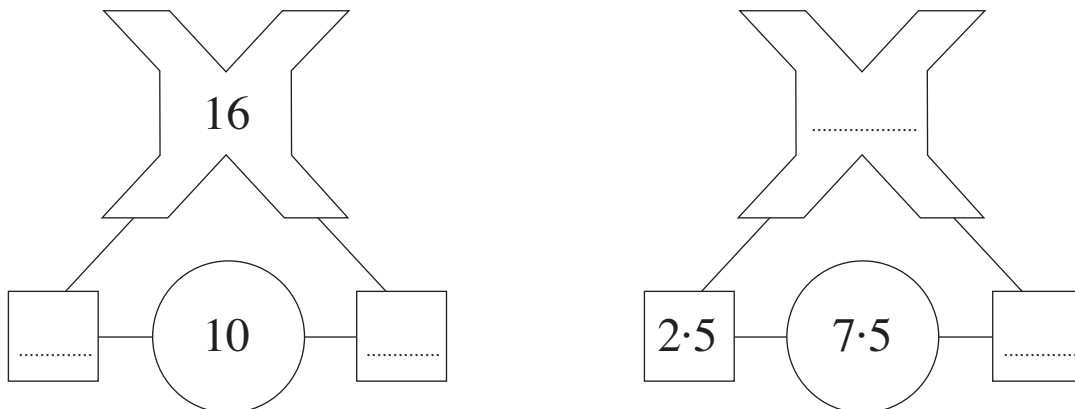

[2]

- (b) Using the same rules, complete the diagram below in terms of x and y .

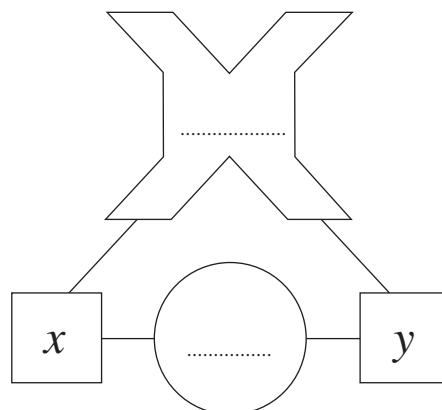

[2]

14.

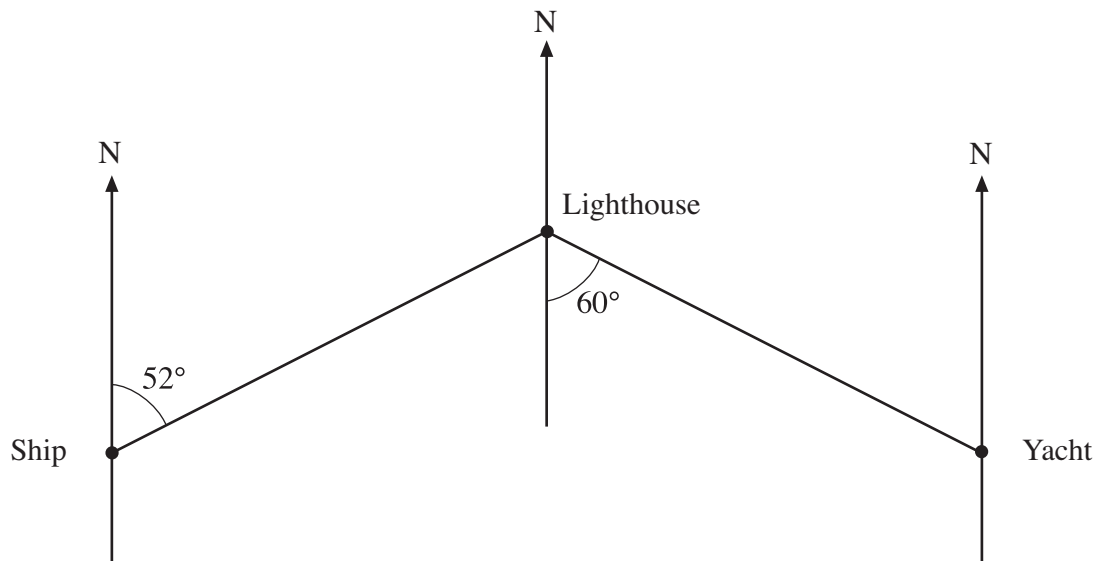

Diagram not drawn to scale.

Write down the bearing of

(a) the yacht from the lighthouse,

..... [1]

(b) the ship from the lighthouse.

.....
 [2]

15. (a) Calculate the circumference of a circle with a radius of 5 cm, using 3.14 as the value of π .

.....

.....

.....

[2]

(b)

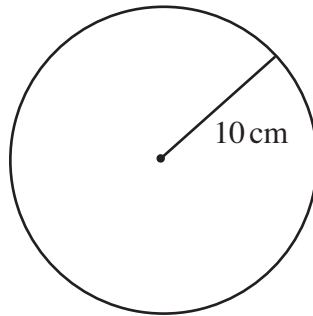

Diagram not drawn to scale.

Calculate the area of the circle shown in the diagram above, using 3.14 as the value of π .

.....

.....

.....

.....

[2]

(c)

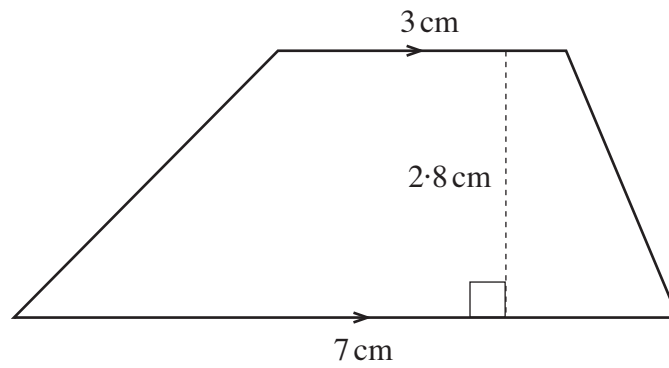

Diagram not drawn to scale.

Calculate the area of the trapezium shown in the diagram.

.....

.....

.....

.....

.....

[2]

16. (a) A sequence starts with 8.
Equal amounts are added each time to get the next term.
Write down the three missing terms of the sequence.

[3]

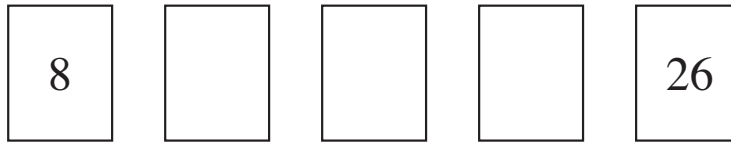

.....

.....

.....

- (b) Write down the n th term of the sequence 8, 13, 18, 23, 28,

.....

.....

.....

[2]

- (c) The diagrams show tile patterns.

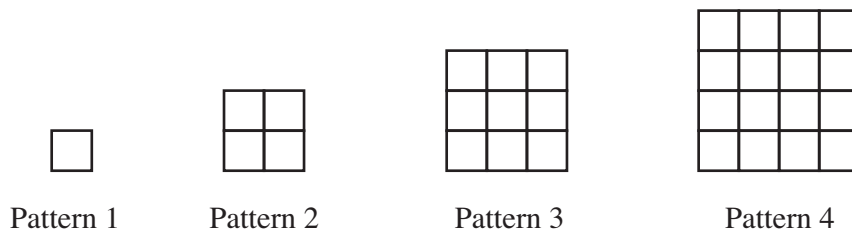

Find an expression for the number of tiles in Pattern n .

.....

.....

.....

[1]

17. (a) Express 792 as a product of prime numbers in index form.

.....

.....

.....

.....

.....

.....

.....

.....

.....

.....

.....

.....

[3]

- (b) Explain why 18 is not a perfect square.

.....

.....

.....

.....

[1]

18. Shade the region that satisfies both of the following conditions.

- (i) The points are less than 4.5 cm from A .
- (ii) The points are nearer to B than to A .

[3]

